

# ProfiLine

professional meal distribution

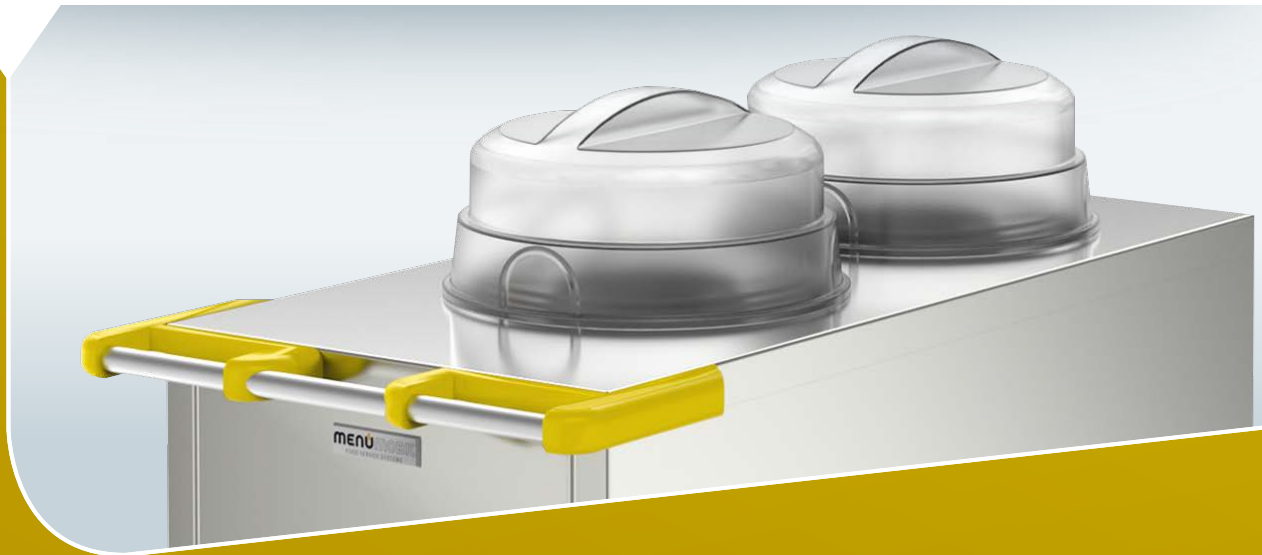

Distribution trolleys,  
platform dispensers and  
more. Ergonomic.  
Functionally advanced.



**menu**MOBIL®  
FOOD SERVICE SYSTEMS

# ProfiLine

## FEATURES

ROBUST. POWERFUL. ERGONOMIC.  
FUNCTIONALLY ADVANCED.

### PROFESSIONAL MEAL DISTRIBUTION

These systems are the professional answer to economic kitchen work with optimum cost/benefit ratio. Equipped with flawless superior attributes. A wide range of distribution carts, plate dispensers, racks, shelf carts and transport carts for the most far-reaching requirements. High capacity and small space requirements. Made completely of chrome-nickel steel. For modern meal-distribution needs. MenuMobil ProfiLine convinces every step of the way.

**Safe. Hygienic. Easy-to-operate.**  
**Everything in one hand.**  
**Perfect meal distribution - with a system!**



## THE SYSTEMS

DIVERSE MODELS IN VARIOUS  
SIZES AND CAPACITIES

### PLATFORM DISPENSER

The Platform dispenser provides the greatest usable stacking surface along with optimum handling, thanks to the MenuMobil pushbar. The ergonomically designed push grips also ensure effective protection against injury to the hands. The height of 900 mm is suited to the effective height of meal distribution.

### BASKET DISPENSER with fan-assisted cooling

Not only to keep warm, also to keep chilled – these are ongoing concerns of kitchen logistics. After all, salads and desserts need to be kept chilled. The Basket dispenser provides safe assurance of chilled meal components while portioning – no heat shock, everything stays at standard HAACP temperature.

### PLATFORM DISPENSER for PN-norm dishware

In the meal distribution channel, all work steps need to be perfectly coordinated to each other. Precision in sequence and timing is what makes it hum. That's why we offer a very specific range of racks, specially designed for PN-norm dishware and PN-norm lids.



### PLATFORM DISPENSER

ART.NO.	NAME	NOTE	MEASUREMENTS (W x D x H)
0180002	Platform Dispenser BDK/57-57-MM	for synthetic parts	appx. 760 x 852 x 900 mm
0180004	Platform Dispenser BDK/85-60-MM	for synthetic parts	appx. 760 x 1172 x 900 mm
0180003	Platform Dispenser BDK/57-57K-MM	for synthetic parts, with cool slits	appx. 760 x 852 x 900 mm
0180005	Platform Dispenser BDUH/60-60/4S-MM	univ. platform, circulatory heating	appx. 760 x 992 x 900 mm
0180036	Platform Dispenser BD/60-60-MM	for dishware elements	appx. 760 x 902 x 900 mm
0180037	Platform Dispenser BD/60-60K-MM	for dishware elementes, with cool slits	appx. 760 x 902 x 900 mm
0180000	Platform Dispenser BD/60-60/4S-MM	univ. platform, unheated	appx. 760 x 992 x 900 mm
0180038	Platform Dispenser BD/60-60/4SK-MM	univ. platform, with cool slits	appx. 760 x 992 x 900 mm

### BASKET DISPENSER with fan-assisted cooling

ART.NO.	NAME	NOTE	MEASUREMENTS (W x D x H)
0180001	Basket dispenser BDC/50-50-MM	circulatory heating	appx. 761 x 1092 x 900 mm

### PLATFORM DISPENSER for PN-norm dishware

ART.NO.	NAME	NOTE	MEASUREMENTS (W x D x H)
0180058	Platform dispenser BPN 4-P-MM	for PN-norm dishware	appx. 710 x 900 x 530 mm
0180059	Platform dispenser BPN 4-D-MM	for PN-norm cover	appx. 741 x 923 x 544 mm

# THE SYSTEMS

DIVERSE MODELS IN VARIOUS SIZES AND CAPACITIES

## BASKET DISPENSER

Stacks baskets of dishware for transport, intermediate storage and readiness. Our basket stacker provides uncomplicated help and organisation. Whether open, closed or with cooling slits. We have the optimum solution for your needs.

## TRAY DISPENSER

Our tray dispenser gives you the help you require. In the customer zone at the self-service counter or in the meal distribution line. Efficient support for kitchen logistics without a single gap.



## PLATE DISPENSER

For stacking, transport and intermediate storage of plates, important parts of every meal distribution. Our plate dispenser support you at every step. In portioning and serving, these stackers provide active, dynamic assistance. Through constant serving height, reaching for a plate is eased greatly.

## UNIVERSAL DISPENSER

Highly varied shapes and sizes of dishware? Round and angular? All of these are aspects of meal distribution. The universal dispenser serves such highly diverse requirements to perfection. With maximum capacity, due to individually adjustable border rods. For distribution without a gap.

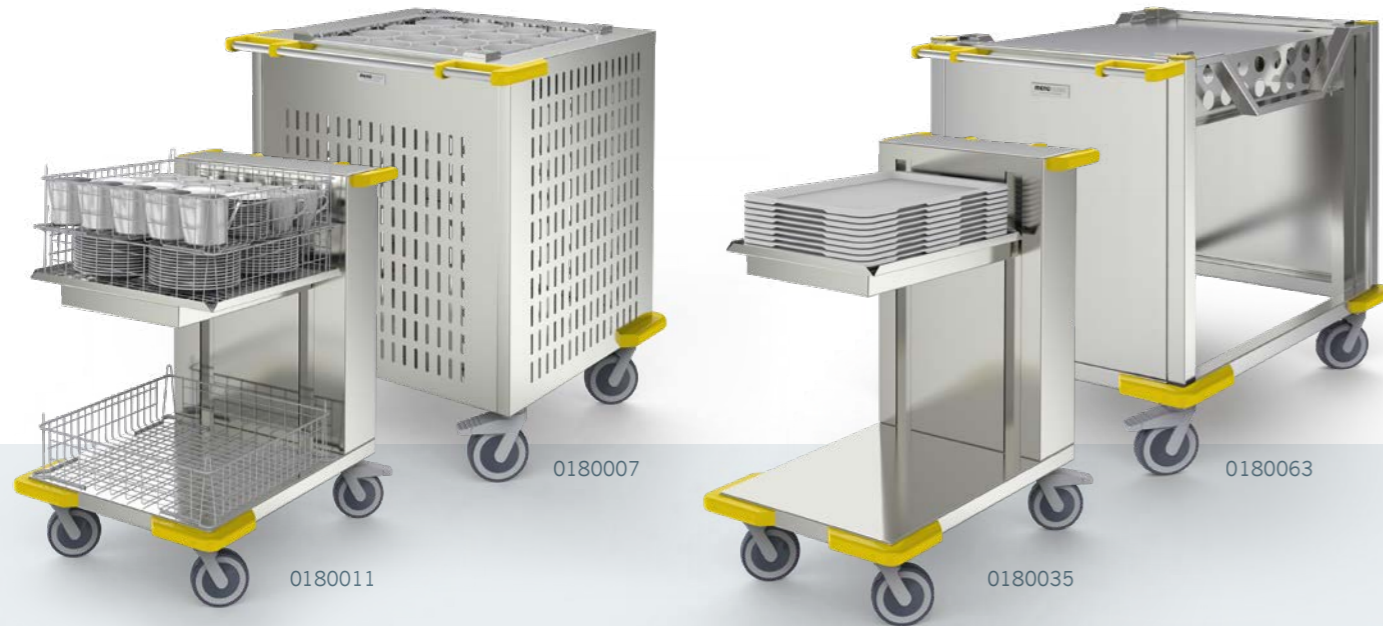

## BASKET DISPENSER

ART.NO.	NAME	NOTE	MEASUREMENTS (W x D x H)
0180011	Basket dispenser OKO/50-50-MM	open, baskets 500 x 500 mm	appx. 560 x 800 x 900 mm
0180012	Basket dispenser OKO/65-53-MM	open, baskets 650 x 530 mm	appx. 715 x 800 x 900 mm
0180006	Basket dispenser KO/50-50-MM	closed, baskets, 500 x 500 mm	appx. 760 x 712 x 900 mm
0180007	Basket dispenser KO/50-50K-MM	cooling slits, baskets 500 x 500 mm	appx. 760 x 712 x 900 mm
0180008	Basket dispenser KO/65-53-MM	closed, baskets 650 x 530 mm	appx. 760 x 852 x 900 mm
0180009	Basket dispenser KOUH/50-50-MM	circulatory heating, baskets 500 x 500 mm	appx. 760 x 852 x 900 mm
0180010	Basket dispenser KOUH/65-53-MM	circulatory heating, baskets 650 x 530 mm	appx. 760 x 992 x 900 mm

## TRAY DISPENSER

ART.NO.	NAME	NOTE	MEASUREMENTS (W x D x H)
0180013	Tray dispenser OTA/47-36-MM	open, universal trays	appx. 510 x 800 x 900mm
0180035	Tray dispenser OTA/53-37-MM	open, trays EN/GN	appx. 510 x 800 x 900mm
0180014	Tray dispenser OTA/53-37S-MM	open, trays EN/GN	appx. 510 x 800 x 900mm
0180060	Tray dispenser OTA/U-BW-MM	automatic stacking	appx. 510 x 820 x 1030mm
0180063	Tray dispenser TA-2/53-37-MM	platform appx.760x540 mm for PH & SysT	appx. 685 x 963 x 909mm
0180025	Tray dispenser TAG-1/53-37-MM	closed, trays EN/GN	appx. 510 x 822 x 900mm

## PLATE DISPENSER

ART.NO.	NAME	NOTE	MEASUREMENTS (W x D x H)
0180026	Plate dispenser TE-2/V 19-26-MM	unheated, 2 dishware racks	appx. 460 x 935 x 900 mm
0180027	Plate dispenser TE-2/VK 19-26-MM	cooling slits, 2 dishware racks	appx. 460 x 935 x 900 mm
0180028	Plate dispenser TEH-1/V 19-26-MM	heated, 1 dishware rack	appx. 460 x 610 x 900 mm
0180029	Plate dispenser TEH-2/V 19-26-MM	heated, 2 dishware racks	appx. 460 x 935 x 900 mm
0180050	Plate dispenser TEUH-2/VS 27-33-MM	circulatory heating, 2 dishware racks	appx. 935 x 460 x 900 mm
0180031	Plate dispenser TEUH-2/VS 19-26-MM	circulatory heating, 2 dishware racks	appx. 935 x 460 x 900 mm

## POWER DISPENSER

ART.NO.	NAME	NOTE	MEASUREMENTS (W x D x H)
0180030	Power dispenser PSUH-226P-MM	circulatory heating, for warmed lower parts	appx. 660 x 981 x 972 mm

## UNIVERSAL DISPENSER

ART.NO.	NAME	NOTE	MEASUREMENTS (W x D x H)
0180032	Universal dispenser UST/57-28-MM	unheated	appx. 510 x 750 x 900 mm
0180033	Universal dispenser UST/57-28K-MM	unheated, with cooling slits	appx. 510 x 750 x 900 mm
0180034	Universal dispenser USTUH/57-28-MM	circulatory heating	appx. 510 x 750 x 900 mm

# THE SYSTEMS

PERFECT SOLUTIONS  
FOR YOUR WORK REQUIREMENTS



# ProfiLine

## MOBILE BAIN MARIE

One to four GN basins - you determine how much capacity you need. We have the wide variety you expect from kitchen logistics professionals. Front-side operation is simple. Robust and reliable overall outfitting. Your dependable assistant in every large-scale kitchen.



0180071



0180022



0180081

## FOOD TRANSPORT TROLLEY

The food transport trolley cart is ideal for meal distribution in limited premises. Even in reduced spaces, this can handle a whole series of requirements. Easy handling, flexible movement, perfect results are assured on each and every plate.

## PLATE TRANSPORT TROLLEY

The MenuMobil plate transport trolley provides the ideal link through higher board, an ergonomically designed and user-friendly removal height for your stored dishware elements.

## TRANSPORT SHELVING UNIT

What would a large-scale kitchen be without shelf carts? Trays, classic boxes, GN holders, baking sheets and chilling trays - everything has room, everything in its place. High capacities, little space requirements. And quick to serve your needs wherever needed. In this segment, we also offer custom-made solutions.

## TRAY TRANSPORT TROLLEY

The tray transport trolley provides effortless handling for persons of every height, through its small space needs and four full-length slidebars. A variety of rollers provide optimum manoeuvrability.



7760S



0162959



0163879

## MOBILE BAIN MARIE

ART.NO.	NAME	NOTE	MEASUREMENTS (W x D x H)
0180017	Mobile bain marie SPA/EB-1-MM	1 basin GN1/1, open	appx. 604 x 677 x 900mm
0180070	Mobile bain marie SPA/EB-2-MM	2 basins GN1/1, open	appx. 914 x 677 x 900mm
0180071	Mobile bain marie SPA/EB-3-MM	3 basins GN1/1, open	appx. 1254 x 677 x 900mm
0180020	Mobile bain marie SPA/EB-4-MM	4 basins GN1/1, open	appx. 1594 x 677 x 900mm
0180015	Mobile bain marie SPA/K-2-MM	DW cooled, 1 basin 510x630 mm	appx. 719 x 874 x 900mm
0180016	Mobile bain marie SPA/K-3-MM	DW cooled, 1 basin 510x955mm	appx. 719 x 1199 x 900mm

## FOOD TRANSPORT TROLLEY

ART.NO.	NAME	NOTE	MEASUREMENTS (W x D x H)
0180022	Food transport trolley SPTW-2-MM	EDF 2 basins 1/1, 2 warm compartments	appx. 700 x 922 x 974 mm
0180024	Food transport trolley SPTW-3-MM	EDF 3 basins 1/1, 2 warm compartments	appx. 700 x 1317 x 974 mm
0180021	Food transport trolley SPTW-2-MM	cover, 2 warm compartments	appx. 673 x 942 x 900 mm
0180023	Food transport trolley SPTW-3-MM	cover, 3 warm compartments	appx. 673 x 1335 x 900 mm

## PLATE TRANSPORT TROLLEY

ART.NO.	NAME	NOTE	MEASUREMENTS (W x D x H)
0180081	Plate transport trolley TETW/h PN-Norm	2/PN double loadable, 10 compartments	appx. 725 x 966 x 1173 mm

Additional plate trolleys, e.g. singly loadable, available in diverse sizes on request.

## TRANSPORT SHELVING UNIT

ART.NO.	NAME	NOTE	MEASUREMENTS (W x D x H)
7760S	Transport shelving unit CNS shelf cart	for upper, lower parts, trays	appx. 1275 x 625 x 1810 mm
0121279	Transport shelving unit	for lids	appx. 1250 x 650 x 1800 mm

## TRAY TRANSPORT TROLLEY

ART.NO.	NAME	NOTE	MEASUREMENTS (W x D x H)
0162959	Tray transport trolley TTW/M 2/32 EN-115-B PK	with passive chilling	appx. 1369 x 892 x 1336 mm
0163879	Tray transport trolley TTW/CS 1/20 EN 115-B PK	thermically separated	appx. 798 x 947 x 1606 mm

Additional TTW model possibilities available on request.

## MORE PRODUCTS BY PROFILINE:

The quality of meal distribution depends on two factors: the talent and creativity of the large-scale kitchen, on the one hand; and the manner of distribution and presentation of the meals, on the other. Only if the quality and taste produced in the kitchen actually arrives at the guest is he/she satisfied. For more than 30 years MenuMobil has worked on and perfected the art of meal distribution, providing innovative solutions for the most wide-ranging work requirements. In addition to the ProfiLine system presented above, we also have other products available in the customary high quality.

- Transport shelving units
- General purpose trolleys
- Basket dispensers
- Dishware baskets
- Gastro-norm containers
- Platform trolleys
- Breakfast trolleys
- Banquet trolleys
- Meal transport boxes
- Eutectic plates
- Eutectic plate trolleys
- Meal make-up conveyors
- and lots more...



# Perfect meal distribution - with a system

With the multi-faceted product range of MenuMobil you have the right system for every type of use.

**ClassicLine**

unique & innovative

**menuMOBIL**  
FOOD SERVICE SYSTEMS

## ClassicLine

- Classic
- EcoClassic
- Universal

The compact transport system provides optimum insulation of chilled and hot meal components for perfect-temperature enjoyment. Hygienic. Attractive. Economic.

**Inducook**

ClassicLine  
simple & revolutionary

**menuMOBIL**  
FOOD SERVICE SYSTEMS

## Inducook ClassicLine

Transported chilled - served hot. The simple-to-operate induction technology heats only the appropriately coated dishware, while salads and desserts remain cool. That way, the overall taste experience of a meal is ensured.

**InductLine**

induction technology perfected

**menuMOBIL**  
FOOD SERVICE SYSTEMS

## InductLine

- Indock

Innovative induction technology combined with tray-transport trolley. Through electronic control the meals are regenerated to the desired temperature, plannable right to the minute.

**AirLine**

individually heated

**menuMOBIL**  
FOOD SERVICE SYSTEMS

## AirLine

- UNITRAY
- DSPRO
- EVOMULTI Buffet

Heating and active chilling – all in one transport trolley. Meals are heated with hot air and desserts and salads are chilled separately via electronic control.

**ContactLine**

punctually and economically heated

**menuMOBIL**  
FOOD SERVICE SYSTEMS

## ContactLine

This is contact-heating with intelligent temperature sensors integrated into the tray. Via heating zones, precisely targeted energy flows to the dishware for hot meal components. In the service trolley, only the trays in use receive energy supply.

**ProfiLine**

professional meal distribution

**menuMOBIL**  
FOOD SERVICE SYSTEMS

## ProfiLine

Robust, mature, intelligent – with a wide-ranging program of serving trolleys, plate dispensers, racks and transport carts, we provide professional perfection for economic kitchen work at optimum cost/benefit ratio.

A COMPANY OF THE HUPFER CORPORATE GROUP:

**HUPFER**  
we make work flow

**menuMOBIL**  
FOOD SERVICE SYSTEMS

**RÜTHER**  
Food-Präsentation & Ausgabetechnik

**trak**  
Catering Solutions

**menuMOBIL**  
FOOD SERVICE SYSTEMS

**MenüMobil Food Service Systems GmbH**

Dr. Gustav-Markt-Weg 18 | A-6401 Inzing | Tirol

Tel.: +43/(0) 52 38 / 88 661 | Fax: +43/(0) 52 38 / 88 778

www.menu-mobil.com | office@menu-mobil.com

Subject to technical modifications.

Concept and design: in:tm advertising agency © menu mobil werbeagentur - telef. 0043 / (0) 664 / 308 44 35  
Fotos: MenuMobil Food Service Systems GmbH, Hupfer, Metalwerke GmbH & Co. KG, Gerhard Wolkersdorfer, Stockphoto, Adobe Stock